



**Product Features**

- Certified to EN 1433 Load Class C - 56,000 lbs - 1,162 psi
- Uses 'QuickLok' boltless locking system
- Suitable for use with K200, KS200, H200K-13, and H200KS-13 channels
- Manufactured from ductile iron to ASTM A 536-84 - Grade 65-45-12
- E- coated for improved resistance against rust
- Complies with ADA - American Disabilities Act of 1990 Section 4.5.4
- Bicycle Tire Penetration Resistant to AS 3996 - 2006



ACO Specification Information

**Specifications**

**General**

The surface drainage system shall be ACO Drain K200, KS200, H200K-13, and H200KS-13, channels\* complete with ACO Type 680Q Wave ductile iron grate with 'QuickLok' locking as manufactured by ACO Polymer Products, Inc. or similar approved.

**Materials**

The covers shall be manufactured from ductile iron and have **minimum** properties as follows:

- **Independently certified to meet Load Class C to EN 1433 - 56,000 lbs - 1,162 psi**
- **Ductile iron to ASTM A 536-84 - Grade 65-45-12**
- **Intake area of 58.72 sq. in. (378.84 cm<sup>2</sup>) per half meter of grate**

The overall width of 9.41" (239mm) and overall length of 19.69" (500mm). Slots measure at a maximum of 0.43" (11mm).

**Installation**

The trench drain system and grates shall be installed in accordance with the manufacturer's installation instructions and recommendations.

\* delete as appropriate

Supplied By:



877-903-7246

www.trenchdrainsupply.com



# ACO DRAIN

## Type 680Q Wave ductile iron grate



ACO Specification Information

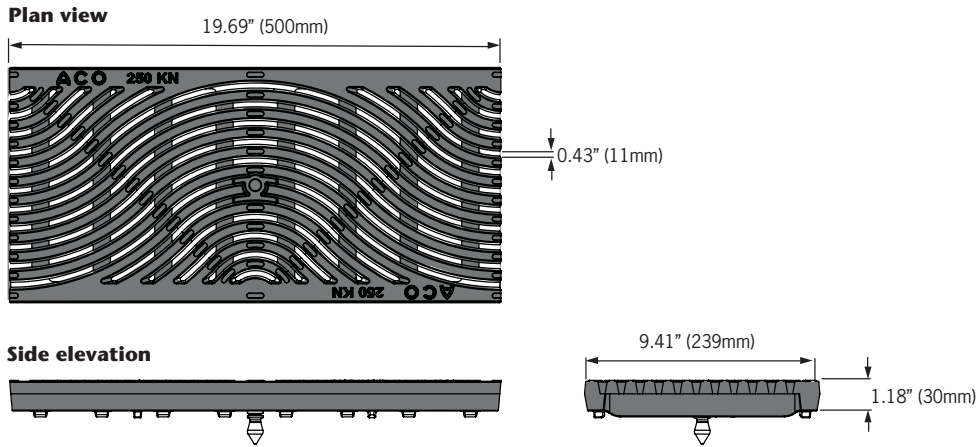

Description	Part No.	Length inches (mm)	Width inches (mm)	Weight lbs.
QuickLok grate				
Type 680Q Ductile iron wave grate	93955	19.69 (500)	9.41 (239)	28.0
QuickLok locking bar	10457	-	-	0.5
QuickLok grate removal tool	01318	-	-	0.3

### 'QuickLok' locking mechanism

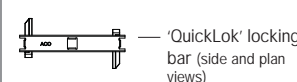
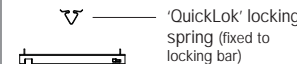
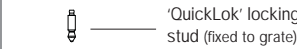
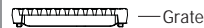
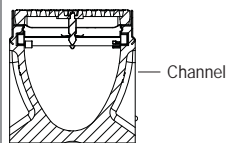

ACO 'QuickLok' is a patented boltless locking system, grates are removed and replaced with the minimum time and effort for ease of maintenance. The unique design provides a positive 'snap down' fit into the locking bar. A stud is fixed to the grate which 'locks' into the spring clip in the locking bar.

The 'QuickLok' stud is made from stainless steel and high density nylon, the locking bar and clip are stainless steel, for use in both general purpose and corrosive environments.

Supplied By:

**TRENCH DRAIN SUPPLY**  
877-903-7246  
www.trenchdrainsupply.com

#### ACO Polymer Products, Inc.

**Northeast Sales Office**  
P.O. Box 245  
Chardon, OH 44024  
Tel: (440) 285-7000  
Toll free: (800) 543-4764  
Fax: (440) 285-7005

**West Sales Office**  
P.O. Box 12067  
Casa Grande, AZ 85130  
Tel: (520) 421-9988  
Toll Free: (888) 490-9552  
Fax: (520) 421-9899

**Southeast Sales Office**  
4211 Pleasant Road  
Fort Mill, SC 29708  
Toll free: (800) 543-4764  
Fax: (803) 802-1063

#### Follow us on



**Electronic Contact:**  
info@ACODrain.us  
www.ACODrain.us

**SPEC INFO**  
**ACO**

© April 10, 2013 ACO Polymer Products, Inc. This information is believed to be accurate but it is not guaranteed to be so. We cannot assume liability for results that buyer obtains with our product since conditions of use are beyond the control of the company. It is the customer's responsibility to evaluate suitability and safety of product for his own use. ACO Polymer Products Inc. reserves the right to change the product and specifications without notice.

Apr 13/2

www.ACODrain.us